

•ilex

LINE

TABLE





The tables are available in three heights with round or square tops in different sizes and materials. Both the tops and the bases, are available in a wide range of finishes that allow multiple combinations facilitating its integration in multiple meeting, hospitality or domestic spaces.

line

Line is a collection of versatile tables that stand out by its timeless and essential design.



dimensions line



Technical info/

Base: Laser cut part + Ø60 x 1,5 mm Metal Tube + Plastic glide is used under the leg.

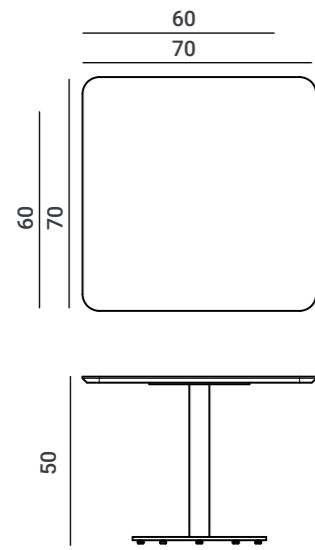

BASE FINISH			
✓	Electrostatic Powder Coated		
✓	Powder Coated + Cataphoresis		
TOP FINISH			
✓	Marble		
✓	Mdf Lam		
✓	Veener		18
✓	Lacquer		
✓	Compact		12
✓	Ceramic		
✓	Glass		10
PACKAGING INFORMATION / H50 CM			
Size	60x60	70x70	
Box Cbm (m³)	0.12	0.13	
Net Weight (kg)	14.9	16.6	
Gross Weight (kg)	19.6	22.2	
Container 40 HC(Pcs)	600	580	

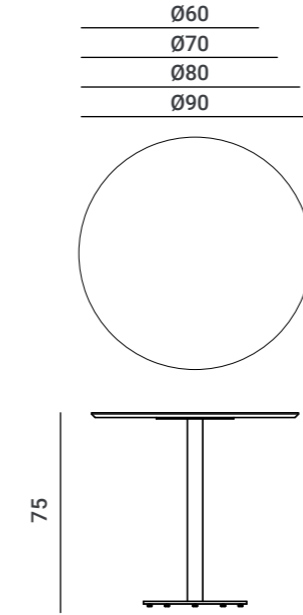

BASE FINISH			
✓	Electrostatic Powder Coated		
✓	Powder Coated + Cataphoresis		
TOP FINISH			
✓	Marble		
✓	Mdf Lam		
✓	Veener		18
✓	Lacquer		
✓	Compact		12
✓	Ceramic		
✓	Glass		10
PACKAGING INFORMATION / H75 CM			
Size	Ø60	Ø70	Ø80
Box Cbm (m³)	2.34	2.9	2.34
Net Weight (kg)	49	56	49
Gross Weight (kg)	67	74	67
Container 40 HC(Pcs)	24	18	24

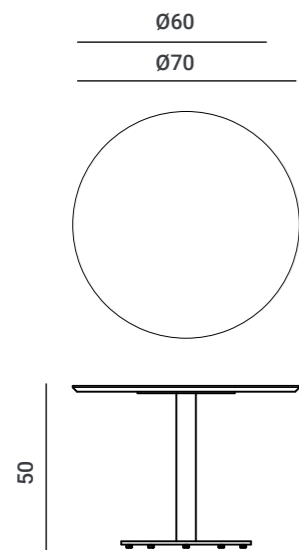

BASE FINISH			
✓	Electrostatic Powder Coated		
✓	Powder Coated + Cataphoresis		
TOP FINISH			
✓	Marble		
✓	Mdf Lam		
✓	Veener		18
✓	Lacquer		
✓	Compact		12
✓	Ceramic		
✓	Glass		10
PACKAGING INFORMATION / H50 CM			
Size	Ø60	Ø70	
Box Cbm (m³)	0.12	0.13	
Net Weight (kg)	14.9	16.6	
Gross Weight (kg)	19.6	22.2	
Container 40 HC(Pcs)	600	580	

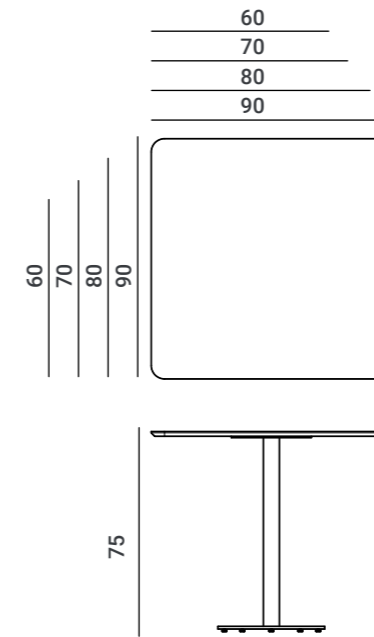

BASE FINISH			
✓	Electrostatic Powder Coated		
✓	Powder Coated + Cataphoresis		
TOP FINISH			
✓	Marble		
✓	Mdf Lam		
✓	Veener		18
✓	Lacquer		
✓	Compact		12
✓	Ceramic		
✓	Glass		10
PACKAGING INFORMATION / H75 CM			
Size	60x60	70x70	80x80
Box Cbm (m³)	1.3	1.62	1.96
Net Weight (kg)	30	38	43
Gross Weight (kg)	42.7	52	58
Container 40 HC(Pcs)	42	36	33

dimensions
line



Technical info/

Base: Laser cut part + Ø60 x 1,5 mm Metal Tube + Solid Metal + Plastic glide is used under the leg.

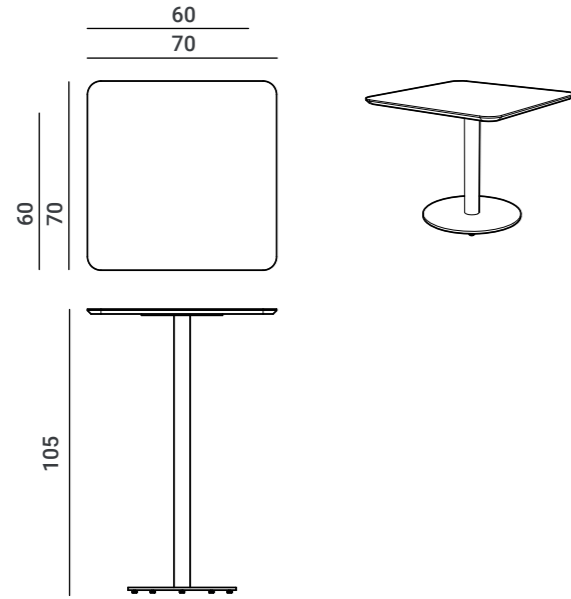

BASE FINISH			
✓	Electrostatic Powder Coated		
✓	Powder Coated + Cataphoresis		
TOP FINISH			
✓	Marble		18
✓	Mdf Lam		
✓	Veener		
✓	Lacquer		
✓	Compact		12
✓	Ceramic		10
✓	Glass		
PACKAGING INFORMATION / H105 CM			
Size	60x60	70x70	
Box Cbm (m³)	0.29	0.3	
Net Weight (kg)	18.9	20.6	
Gross Weight (kg)	23.6	26.2	
Container 40 HC(Pcs)	260	240	

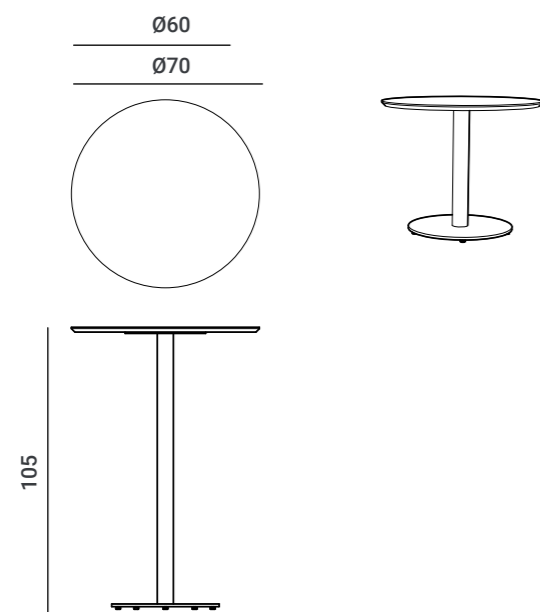

BASE FINISH			
✓	Electrostatic Powder Coated		
✓	Powder Coated + Cataphoresis		
TOP FINISH			
✓	Marble		18
✓	Mdf Lam		
✓	Veener		
✓	Lacquer		
✓	Compact		12
✓	Ceramic		10
✓	Glass		
PACKAGING INFORMATION / H105 CM			
Size	Ø60	Ø70	
Box Cbm (m³)	0.29	0.3	
Net Weight (kg)	18.9	20.6	
Gross Weight (kg)	23.6	26.2	
Container 40 HC(Pcs)	260	240	

• ilex

www.ilex.com.tr

Factory

Esenehir Mah. Muradiye Sok.
No: 38 Ümraniye, İstanbul
E-mail: info@metaliks.com.tr
Phone: +90 216 641 16 06

İstanbul Showroom

Yukarı Dudullu Mah. Çam Sok.
No: 8/12 Ümraniye, İstanbul
E-mail: info@metaliks.com.tr
Phone: +90 537 959 04 04

Export

E-mail: export@metaliks.com.tr
Phone: +90 506 449 47 49